

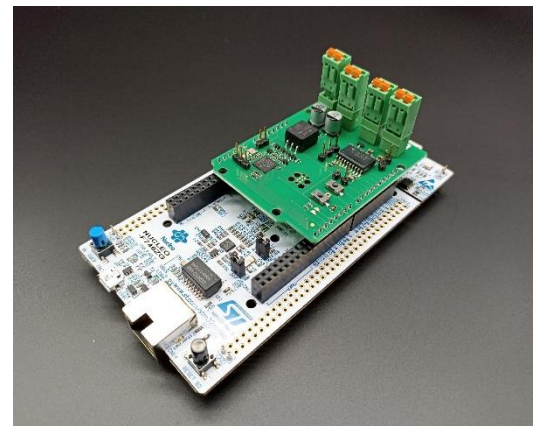

Your independent, freer, more interoperable IoT and AI platform

The babi-lon platform offers the most scalable development environment for your IoT applications because it is available on Linux and FreeRTOS, the most open because it **complies with ISO 14908 and ISO 16484**, the most resource-efficient because **you choose your processor ARM** and it **consumes only 1.5W** for you IP application over twisted pair **without using a single specific component**.

Lon has been associated with Neuron Chips for many years. This solution was too small for innovative solutions. With this new platform you can choose the resource you need for your business application. Your products achieve a small footprint and low price based on FreeRTOS for a large number of sensors and actuators. Or you can opt for LINUX using AI and powerful machine learning applications. Both solutions are based on the same software architecture and always use the proven interoperable LON protocol on different media.



The babi-lon platform now offers the **most flexible** solution because your development will be functional under Linux for powerful applications or under FreeRTOS for **low energy field applications**.

Compatible with all Lon projects and products

All developments carried out in the babi-lon environment can use the SNVT and UNVT network variables as well as the configurations by SCPT or UCPT. It is possible to create your self-installation tool, use an LNS tool or Niagara©. All medium like Ethernet/IP, Wifi, twisted pair (TP/FT10), HD-PLC, can be used and shared on same project with existing routers.

You can develop sensors, actuators or controllers respecting "LonMark profiles" in order to be interoperable with existing installations and to parallel BACnet objects **BTL certified**. Using babi-lon will **not require a gateway** and **will reduce development and implementation engineering costs**.

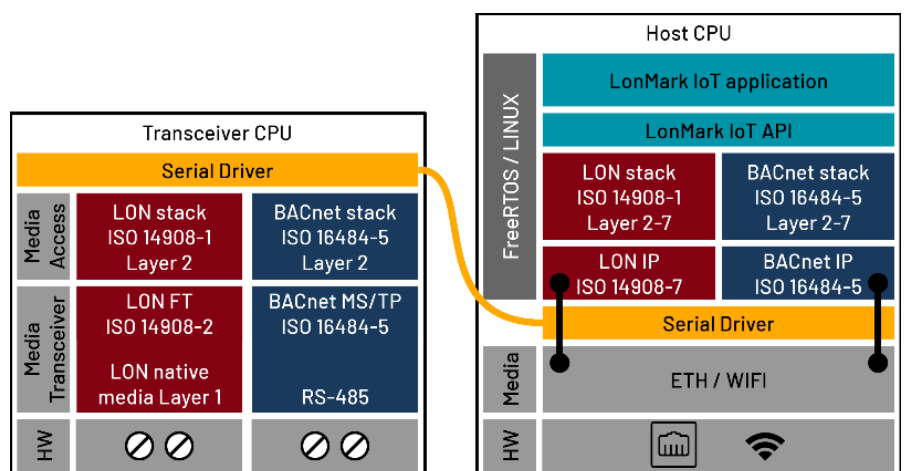

The most economical IP on the market

The babi-lon solution is a brick of the LonMark IoT ecosystem compliant with the **EN 14908-7** standard which associates an IP address with each node. The babi-lon platform on the media over twisted pair **consumes 2 to 6 times less than the solution over Ethernet / IP**. It should be preferred for applications that are deployed in large quantities such as in buildings or environmental measurement sensors.

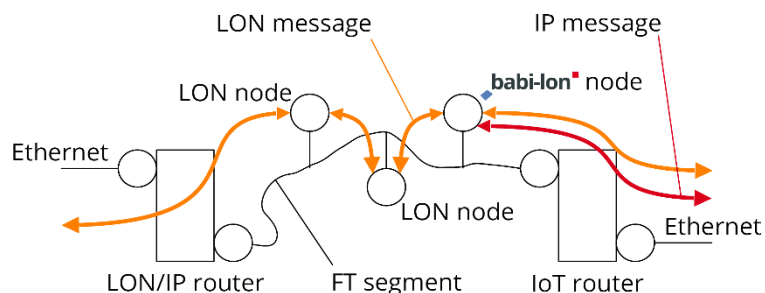

Machine learning and AI embedded with IoT

For the first time since more than 30 years AI and Machine Learning can be reach embedded IoT and LON applications at the same time. By the large range of ARM CPU you can choose the RAM and Flash size to adapt your design to your new business application. A lot of powerful libraries can run on each platform FreeRTOS or Linux.

Other protocols supported and scalable platform

Today, this platform offers the most important evolution never before presented with standardized communication protocols like LON (ISO 14908-7), BACnet (ISO 16484-5) and native IP. On request ModBus/UDP, KNX/IP, SNMP can be implement on FreeRTOS for having the lowest embedded devices consumption or powerful solution on Virtual Machine.

Support

SafeSquare (Germany) and Occitaline (France) provide you with assistance with your development, training in protocols and the environment or manufacture your OEM products.

SafeSquare GmbH

Am Graben 2-6

42477 Radevormwald

Germany

Contact: Martin Mentzel, +49 2191 56814 41, martin.mentzel@safesquare.eu



OCCITALINE

13 Rue Antoine de Lavoisier

31830 Plaisance du Touch

France

Contact: Daniel ZOTTI, +33 5 34 28 12 23, daniel.zotti@occitaline.com

